

EC1300SXIII

◆外形図 General view

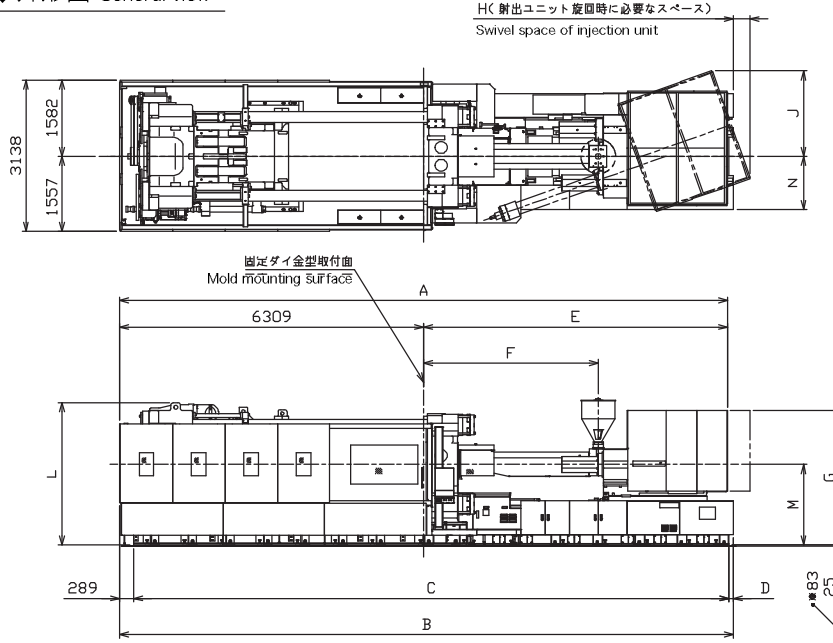

◆取出機取付部 Take-out robot mounting surface

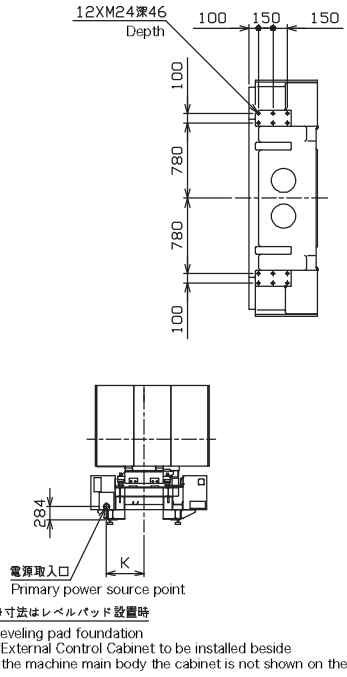

◆金型取付関係図 Mold mounting space

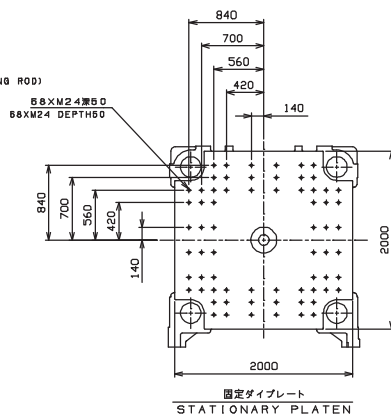
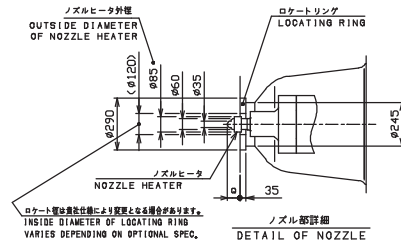
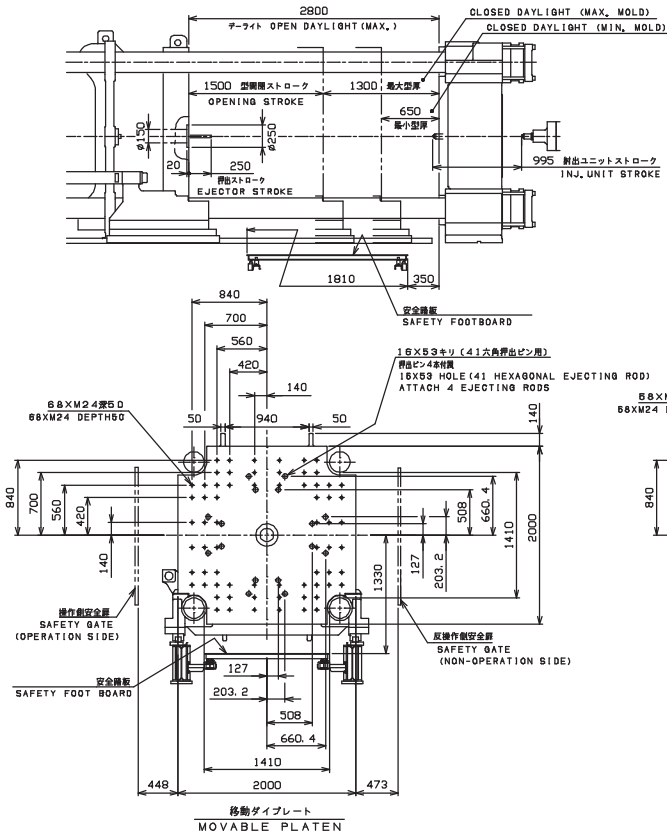

65	標準仕様 (STANDARD SPEC.)
100	オプション仕様 (OPTIONAL SPEC.)
135	
170	

ノズル突出量
NOZZLE PROJECTION

射出ユニット Injection Unit	A	B	C	D	E	F	G	H	J	K	L	M	N
1120A	12609	12727	12348	90	6300	2623~3618	2790	343	1774	780	3080	1670	1100
1120B	12809	12727	12348	90	6500	2823~3818	2790	543	1774	780	3080	1670	1100
1155A	13039	13067	12538	240	6730	2823~3898	3090	477	2083	1040	3325	1915	1360
1155B	13381	13067	12538	240	7072	3165~4240	3090	819	2083	1040	3325	1915	1360