

EC100SXIII

◆外形図 General view

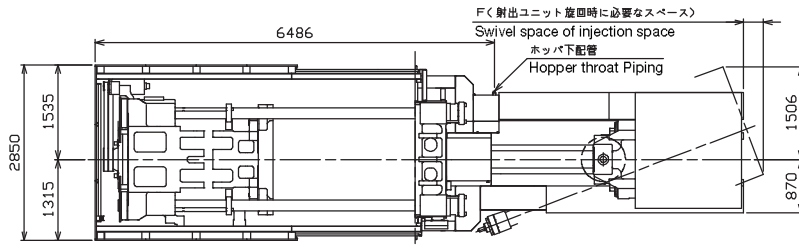

◆取出機取付部 Take-out robot mounting surface

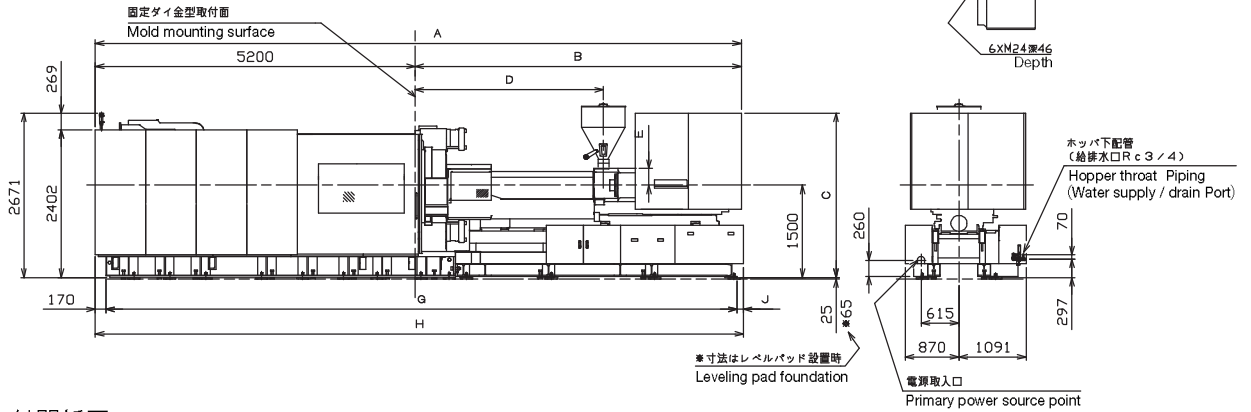

◆金型取付関係図 Mold mounting space

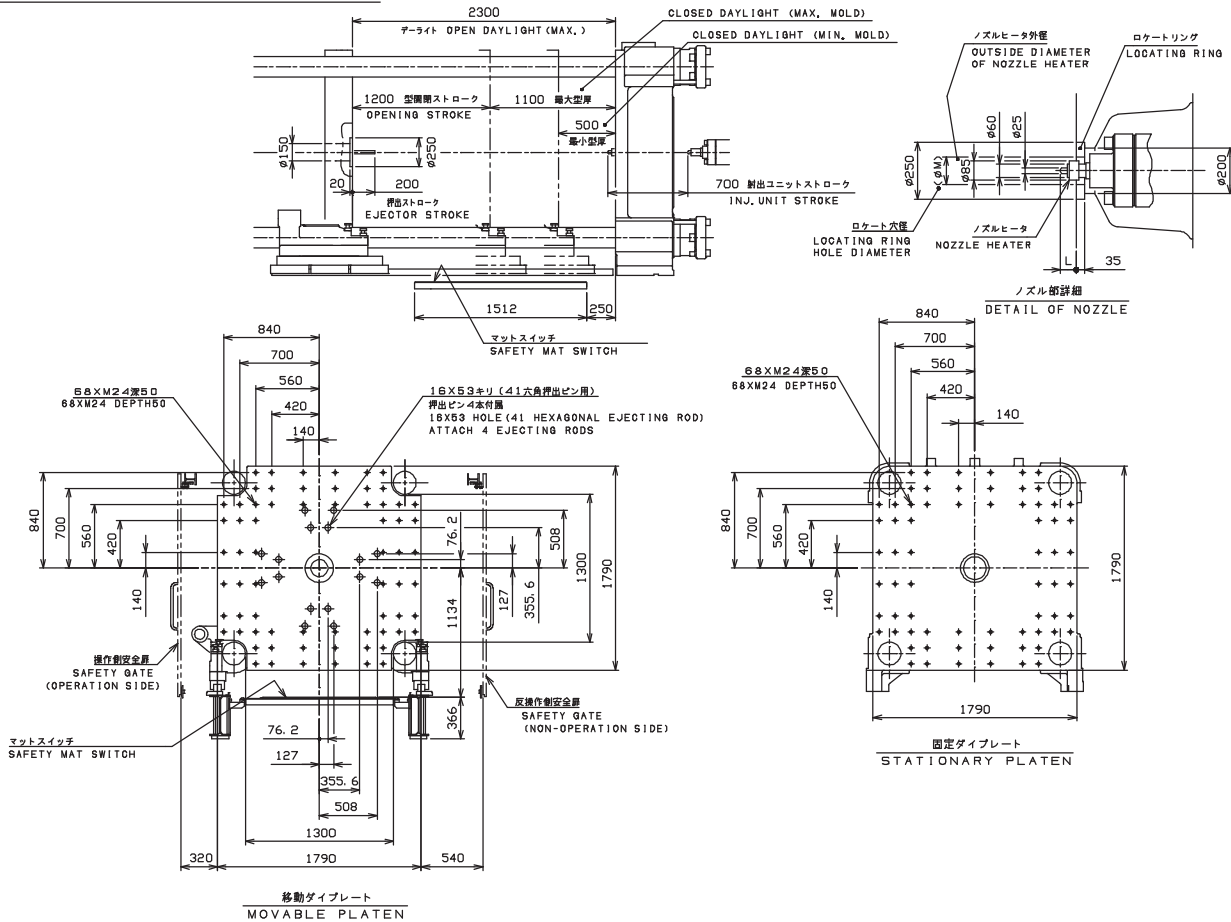

射出ユニット Injection Unit	A	B	C	D	E	F	G	H	J
i61A	10070	4870	2626	2132-2832	230	-88	10265	10935	500
i61B	10270	5070	2626	2332-3032	230	112	10265	10935	500
i78A	10502	5302	2676	2359-3059	275	329	10265	10935	500
i78B	10802	5602	2676	2659-3359	275	629	10265	10935	500

ノズル突出量 (L) NOZZLE PROJECTION		ロケット穴径 (M) ROCKET HOLE DIAMETER	
標準 (STD)	65	標準 (STD)	φ120
選定仕様 (OPTION)	100	選定仕様 (OPTION)	φ150
選定仕様 (OPTION)	135		
選定仕様 (OPTION)	170		